

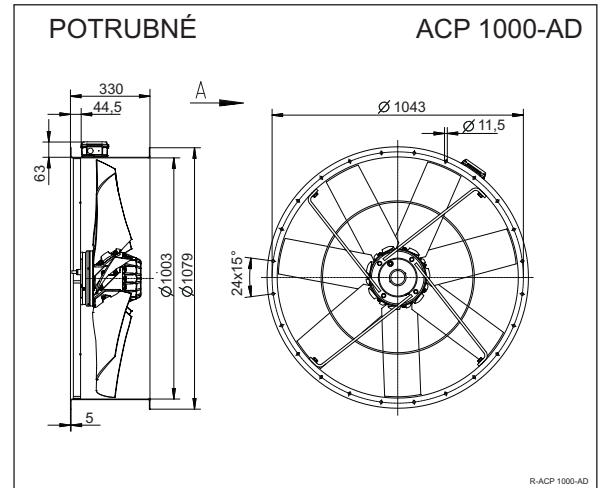

ACS/ACP 1000-AD

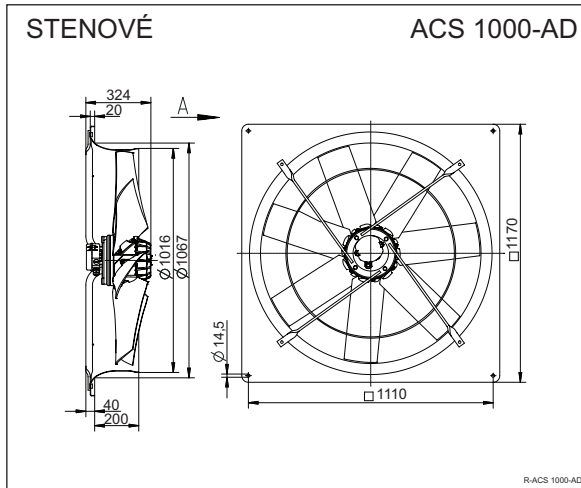

Pripojenie 400V 50Hz
 Príkion 2,2/1,5 kW
 Prúd Δ 4,2/Y2,7 A
 Otáčky 670/530 min⁻¹
 Teplota vzduchu max. 70 °C
 Prietok vzduchu max. 34500 m³/h
 Hmotnosť 70,2 kg/76,1kg
 Regulácia 5° napät'ová
 Schéma zapojenia 108XB

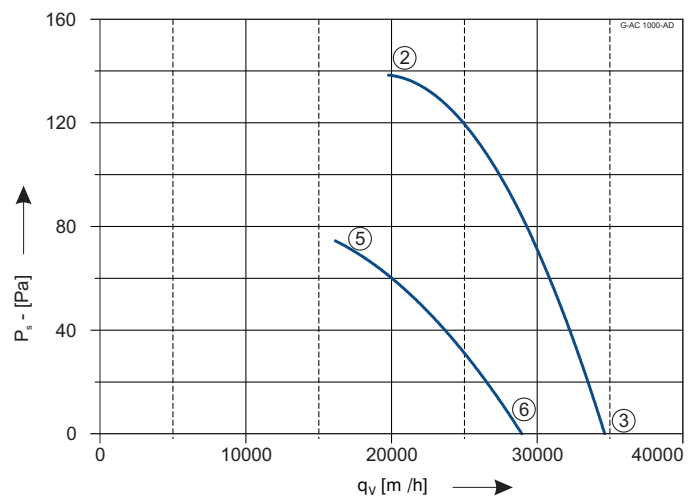

	U	I	P ₁	n
	V	A	W	min ⁻¹
②	400	4,2	2200	670
③		3,8	1800	690
⑤	400	2,7	1500	530
⑥		2,4	1350	570

	②	③	⑤	⑥
L _{WA}				
dB	86	87	80	82

<p>Pretlaková žalúzia</p> <p>SVK 1000</p>	<p>Relé tepelnej ochrany pre zapojenie do Δ</p> <p>STDT 16E</p>	<p>5° regulácia bez termokontaktu pre zapojenie do Δ</p> <p>R-D-5.2G</p>	<p>5° regulácia s termokontaktom pre zapojenie do Δ</p> <p>R-DT5.2KTG</p>	<p>Napät'ový regulátor pre zapojenie do Δ</p> <p>TRT 7D</p>
---	---	--	---	---

Technické zmeny vyhradené. Aktuálne údaje nájdete na www.aircomponents.sk